

Keysight Technologies

HMMC-5032 17.7–32 GHz Amplifier

1GG6-8009

Data Sheet

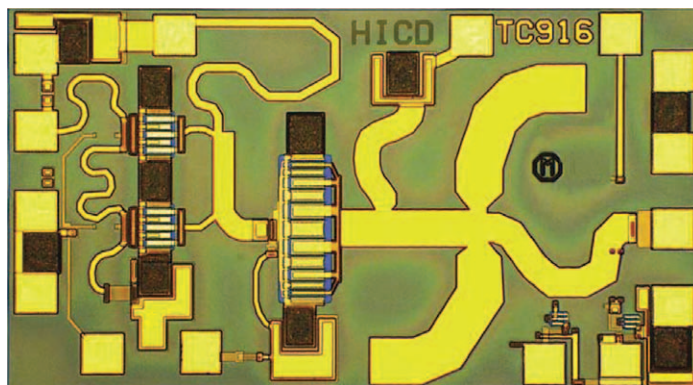

Features

- 22 dBm output $P_{(-1\text{ dB})}$
- 8 dB gain
- 50 Ω input/output matching
- Small size
- Bias: 4.5 volts, 250 mA

Description

The HMMC-5032 is a MMIC power amplifier designed for use in wireless transmitters that operate within the 17.7 GHz to 32 GHz range. It provides 22 dBm of output power and 8 dB of small-signal gain from a small easy-to-use device. The HMMC-5032 was designed to be driven by the HMMC-5040 (20–40 GHz) or the HMMC-5618 (5.9–20 GHz) MMIC amplifier for linear transmit applications. This device has input and output matching circuitry for use in 50 Ω environments.

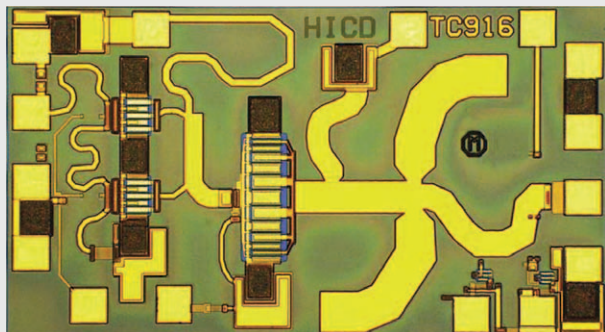

Chip Size:

1370 x 770 μm (53.3 x 30.0 mils)

Chip Size Tolerance:

$\pm 10 \mu\text{m}$ (± 0.4 mils)

Chip Thickness:

$127 \pm 15 \mu\text{m}$ (5 ± 0.6 mils)

Pad Dimensions:

$80 \times 80 \mu\text{m}$ (3.2×3.2 mils)

Absolute Maximum Ratings¹

Symbol	Parameters/conditions	Min.	Max.	Units
$V_{D1,2}$	Drain supply voltages		5	Volts
$V_{G1,2}$	Gate supply voltages	-3.0	0.5	Volts
Det. bias	Applied detector bias (optional)		5	Volts
I_{DD}	Total drain current		460	mA
P_{in}	RF input power		23	dBm
T_{ch}	Channel temperature ²		170	$^{\circ}\text{C}$
T_A	Backside ambient temperature	-55	+95	$^{\circ}\text{C}$
T_{st}	Storage temperature	-65	+170	$^{\circ}\text{C}$
T_{max}	Maximum assembly temperature		300	$^{\circ}\text{C}$

1. Absolute maximum ratings for continuous operation unless otherwise noted.

2. Refer to DC specifications/physical properties table for derating information.

DC Specifications/Physical Properties¹

Symbol	Parameters/conditions	Typ.	Min.	Max.	Units
$V_{D1,2}$	Drain supply operating voltages	4.5	2	5	Volts
I_{D1}	First stage drain supply current ($V_{DD} = 4.5$ V, $V_{G1} \cong -0.8$ V)	100		140	mA
I_{D2}	Second stage drain supply current ($V_{DD} = 4.5$ V, $V_{GG} \cong -0.8$ V)	150		320	mA
$V_{G1,2}$	Gate supply operating voltages ($I_{DD} \cong 250$ mA)	-0.8			Volts
V_P	Pinch-off voltage ($V_{DD} = 4.5$ V, $I_{DD} 10$ mA)	-1.2	-2		Volts
Det. bias	Detector bias voltage (optional)	$V_{D1,2}$		5	Volts
θ_{ch-bs}	Thermal resistance ² (channel-to-backside at $T_{ch} = 160$ °C)	67			°C/watt
T_{ch}	Channel temperature ³ ($T_A = 85$ °C, MTTF > 10^6 hrs $V_{DD} = 4.5$ V, $I_{DD} = 250$ mA)	160			°C

1. Backside ambient operating temperature $T_A = 25$ °C unless otherwise noted.
2. Thermal resistance (°C/watt) at a channel temperature T (°C) can be estimated using the equation: $\theta(T) \cong \theta_{ch-bs} \times [T(°C)+273] / [160 °C+273]$.
3. Derate MTTF by a factor of two for every 8°C above T_{ch} .

RF Specifications

($T_A = 25$ °C, $Z_0 = 50$ Ω , $V_{DD} = 4.5$ V, $I_{DD} = 250$ mA)

Symbol	Parameters/conditions	Low band specifications			Upper band specifications			Units
		Typ	Min	Max	Typ	Min	Max	
BW	Operating bandwidth		17.7	26.5		25	31.5	GHz
Gain	Small signal gain	8	7		7	6		dB
$\Delta\text{Gain}/\Delta T$	Temperature coefficient of gain	0.02			0.02			dB/°C
$P_{-1\text{ dB}}$	Output power at 1 dB gain	22	21		22	21		dBm
P_{SAT}	Saturated output power ¹	24			24			dBm
$(RL_{in})_{Min}$	Minimum input return loss	9	8		15	10		dB
$(RL_{out})_{Min}$	Minimum output return loss	10	9		20	15		dB
Isolation	Minimum reverse isolation	35			30			dB

1. Devices operating continuously beyond 1 dB gain compression may experience power degradation.

Applications

The HMMC-5032 MMIC is a broadband power amplifier designed for use in transmitters that operate in various frequency bands between 17.7 GHz and 32 GHz. It can be attached to the output of the HMMC-5040 (20–40 GHz) or the HMMC-5618 (5.9–20 GHz) MMIC amplifier, increasing the power handling capability of transmitters requiring linear operation.

Biassing and Operation

The recommended DC bias condition is with both drains (VD1 and VD2) connected to single 4.5 volt supply and both gates (VG1 and VG2) connected to an adjustable negative voltage supply. The gate voltage is adjusted for a total drain supply current of typically 250 mA.

The RF input and output are AC-coupled.

An optional output power detector network is also provided. Detector sensitivity can be adjusted by biasing the diodes with typically 1 to 5 volts applied to the det-bias terminal. Simply connecting det-bias to the VD2 supply is a convenient method of biasing this detector network. The differential voltage between the det-ref and det-out bonding pads can be correlated to the RF power emerging from the RF output port.

No ground wires are needed because ground connections are made with plated through-holes to the backside of the device.

Assembly Techniques

It is recommended that the electrical connections to the bonding pads be made using 0.7–1.0 mil diameter gold wire. The microwave/millimeter-wave connections should be kept as short as possible to minimize inductance. For assemblies requiring long bond wires, multiple wires can be attached to the RF bonding pads.

GaAs MMICs are ESD sensitive. ESD preventive measures must be employed in all aspects of storage, handling, and assembly.

MMIC ESD precautions, handling considerations, die attach and bonding methods are critical factors in successful GaAs MMIC performance and reliability.

GaAs MMIC ESD, Die Attach and Bonding Guidelines, Application Note (5991-3484EN) provides basic information on these subjects.

Additional References:

HMMC-5040 and HMMC-5032 Demo, 20–32 GHz High Gain Medium Power Amp - Technical Overview (5989-6449EN)

HMMC-5032 Intermodulation Distortion - Data Sheet (5989-6209EN)

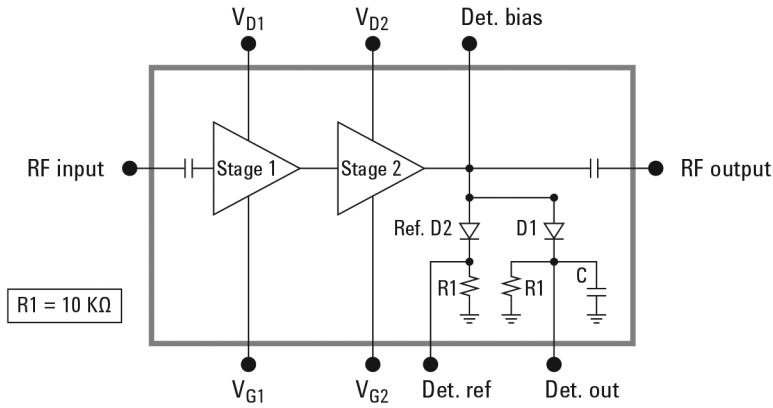

Figure 1. Simplified schematic diagram

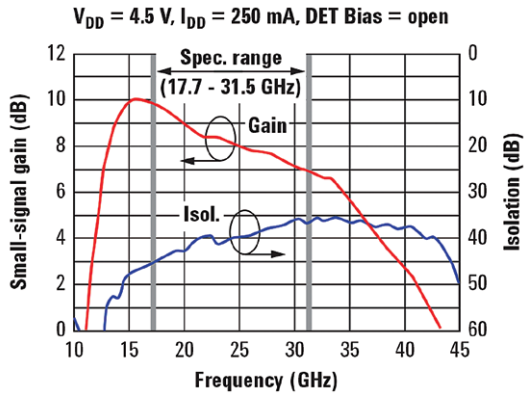

Figure 2. Gain and isolation vs. frequency

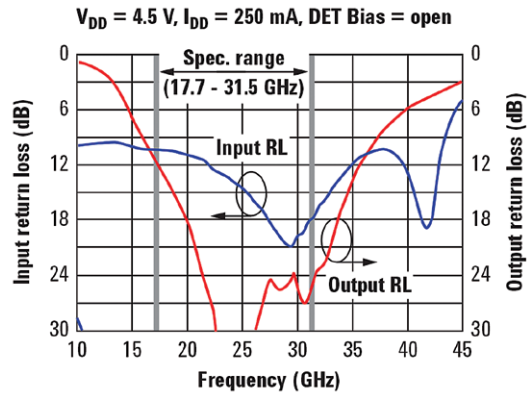

Figure 3. Input and output return loss vs. frequency

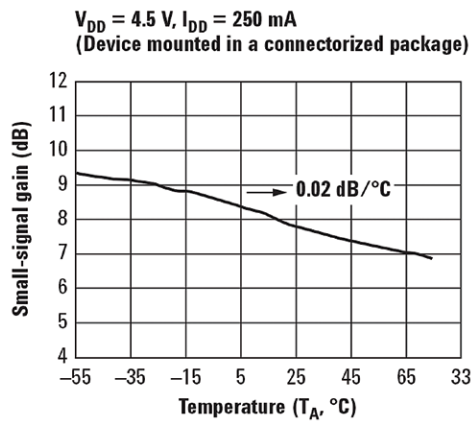

Figure 4. Gain vs. temperature

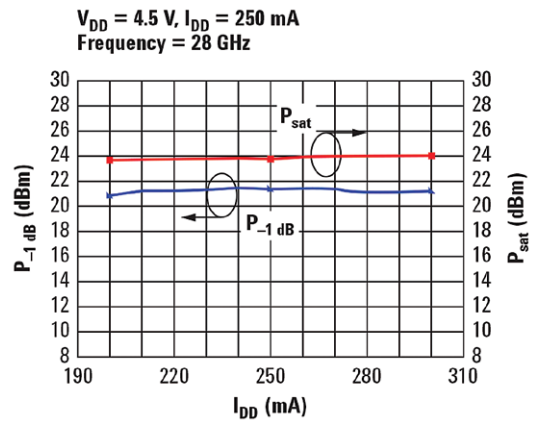

Figure 5. Output power vs. total drain current

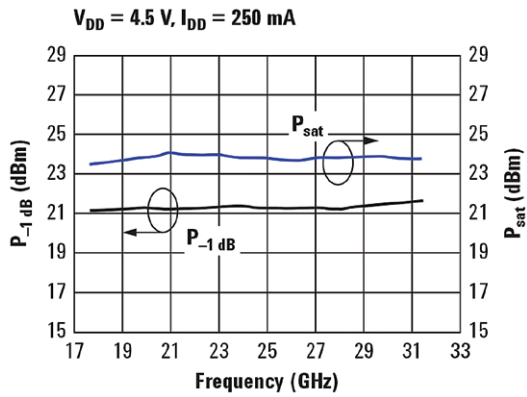

Figure 6. Output power vs. frequency

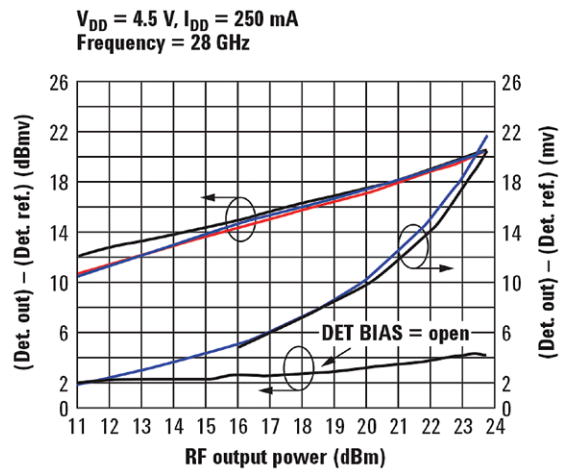

Figure 7. Detector voltages vs. output power for various detector bias voltage

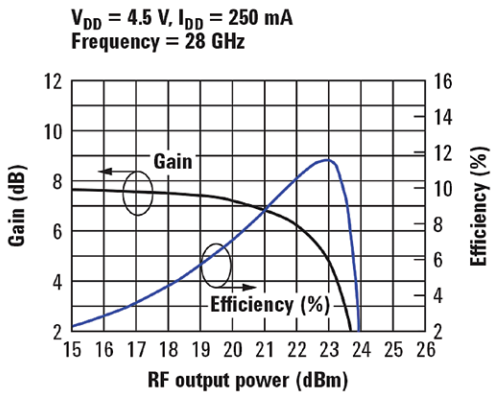

Figure 8. Gain compression and efficiency vs. power out

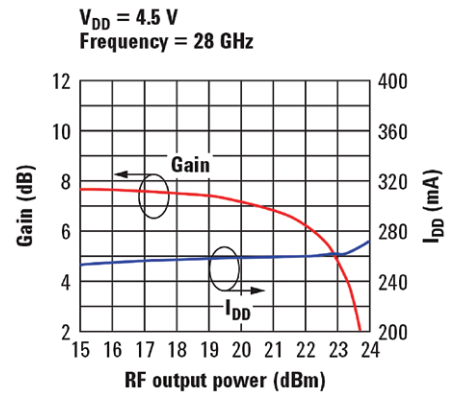

Figure 9. Gain and total drain current vs. output power

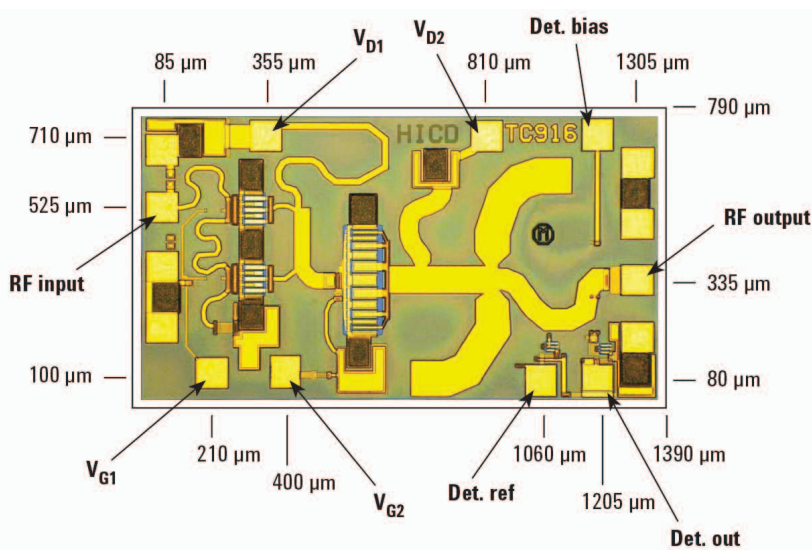

Figure 10. Bonding pad locations

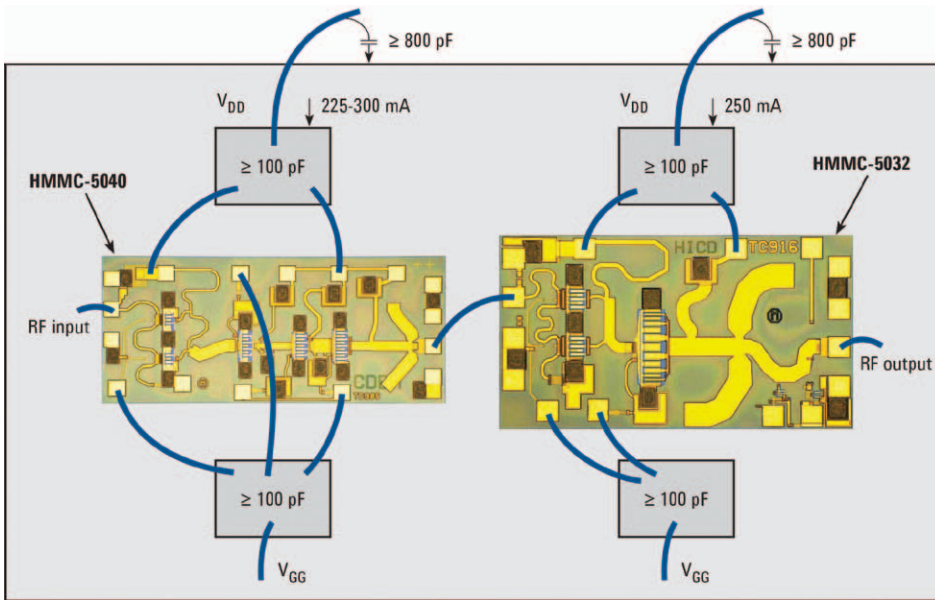

Figure 11. Assembly diagram illustrating the HMMC-5032 cascaded with the HMMC-5040 for 20-32 GHz applications

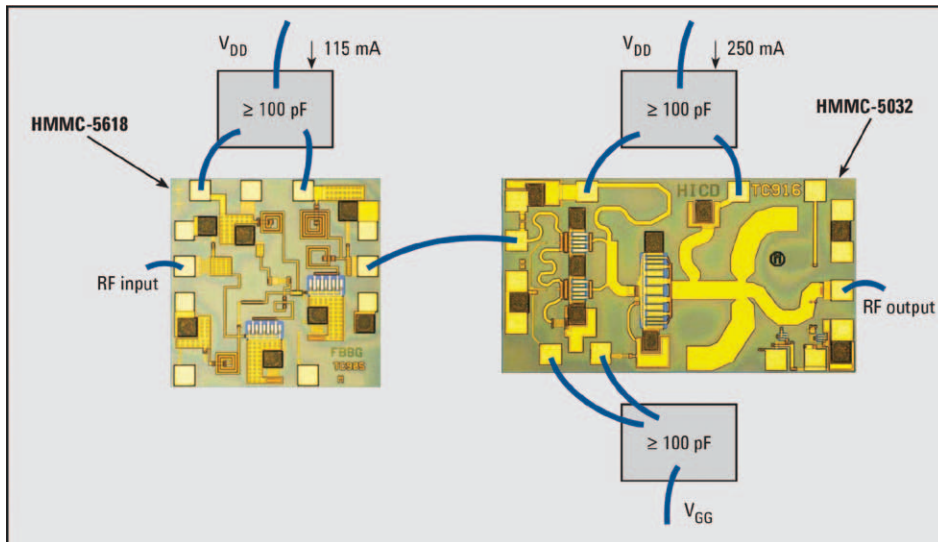

Figure 12. Assembly diagram illustrating the HMMC-5032 cascaded with the HMMC-5618 for 17.7-20 GHz applications

Notes

This data sheet contains a variety of typical and guaranteed performance data. The information supplied should not be interpreted as a complete list of circuit specifications. Customers considering the use of this, or other TCA GaAs ICs, for their design should obtain the current production specifications from Keysight Technologies, Inc.. In this data sheet the term typical refers to the 50th percentile performance. For additional information and support email: mmic_help@keysight.com.

myKeysight

myKeysight

www.keysight.com/find/mykeysight

A personalized view into the information most relevant to you.

Three-Year Warranty

www.keysight.com/find/ThreeYearWarranty

Keysight's commitment to superior product quality and lower total cost of ownership. The only test and measurement company with three-year warranty standard on all instruments, worldwide.



Keysight Assurance Plans

www.keysight.com/find/AssurancePlans

Up to five years of protection and no budgetary surprises to ensure your instruments are operating to specification so you can rely on accurate measurements.



www.keysight.com/quality

Keysight Technologies, Inc.

DEKRA Certified ISO 9001:2008

Quality Management System



Keysight Channel Partners

www.keysight.com/find/channelpartners

Get the best of both worlds: Keysight's measurement expertise and product breadth, combined with channel partner convenience.

www.keysight.com/find/mmic

For more information on Keysight Technologies' products, applications or services, please contact your local Keysight office. The complete list is available at: www.keysight.com/find/contactus

Americas

Canada	(877) 894 4414
Brazil	55 11 3351 7010
Mexico	001 800 254 2440
United States	(800) 829 4444

Asia Pacific

Australia	1 800 629 485
China	800 810 0189
Hong Kong	800 938 693
India	1 800 112 929
Japan	0120 (421) 345
Korea	080 769 0800
Malaysia	1 800 888 848
Singapore	1 800 375 8100
Taiwan	0800 047 866
Other AP Countries	(65) 6375 8100

Europe & Middle East

Austria	0800 001122
Belgium	0800 58580
Finland	0800 523252
France	0805 980333
Germany	0800 6270999
Ireland	1800 832700
Israel	1 809 343051
Italy	800 599100
Luxembourg	+32 800 58580
Netherlands	0800 0233200
Russia	8800 5009286
Spain	0800 000154
Sweden	0200 882255
Switzerland	0800 805353
	Opt. 1 (DE)
	Opt. 2 (FR)
	Opt. 3 (IT)
United Kingdom	0800 0260637

For other unlisted countries:
www.keysight.com/find/contactus
 (BP-07-10-14)